

ID 399ABR_UK	Rev. 02a	Date 28/09/2016	Enviroline[®] 399ABR	Page 1 of 17
-----------------	-------------	--------------------	--------------------------------------	--------------

Enviroline[®] 399ABR – Abrasion Resistant Coating Application Guidelines

Prepared by:

International Paint Ltd.
www.international-pc.com

The information in this guideline is not intended to be exhaustive; any person using the product for any purpose other than that specifically recommended in this guideline without first obtaining written confirmation from us as to the suitability of the product for the intended purpose does so at their own risk. All advice given or statements made about the product (whether in this guideline or otherwise) is correct to the best of our knowledge but we have no control over the quality or the condition of the substrate or the many factors affecting the use and application of the product. THEREFORE, UNLESS WE SPECIFICALLY AGREE IN WRITING TO DO SO, WE DO NOT ACCEPT ANY LIABILITY AT ALL FOR THE PERFORMANCE OF THE PRODUCT OR FOR (SUBJECT TO THE MAXIMUM EXTENT PERMITTED BY LAW) ANY LOSS OR DAMAGE ARISING OUT OF THE USE OF THE PRODUCT. WE HEREBY DISCLAIM ANY WARRANTIES OR REPRESENTATIONS, EXPRESS OR IMPLIED, BY OPERATION OF LAW OR OTHERWISE, INCLUDING WITHOUT LIMITATION, ANY IMPLIED WARRANTY OF MERCHANTABILITY OR FITNESS FOR A PARTICULAR PURPOSE. All products supplied and technical advice given are subject to our Conditions of Sale. You should request a copy of this document and review it carefully. The information contained in this guideline is liable to modification from time to time in the light of experience and our policy of continuous development. It is the user's responsibility to check with their local International Paint representative that this guideline is current prior to using the product.

Protective Coatings

All products supplied and technical advice or recommendations given are subject to our standard Conditions of Sale.



ID 399ABR_UK	Rev. 02a	Date 28/09/2016	Enviroline[®] 399ABR	Page 2 of 17
-----------------	-------------	--------------------	--------------------------------------	--------------

SCOPE AND PURPOSE

The International Paint Application Guidelines have been produced and revised in line with the Worldwide Protective Coatings Product Range. The purpose of the guidelines is to ensure that a lining system, as applied, provides adequate protection against corrosion.

Successful in-service performance of a lining system depends upon both the correct choice of lining and the adoption of the correct guidelines for surface preparation and paint application.

The responsibilities for achieving the specific standards outlined, and for carrying out surface preparation and paint application, rest with the Contracting Company. Under no circumstances do these responsibilities rest with International Paint. We will generally provide for the presence of a Technical Service Representative at key stages during the performance of the contract. The role of the International Paint Technical Service Representative is advisory only unless otherwise specified in the terms and conditions of the contract. The information contained herein presents guidelines for the application of Enviroline 399ABR to both new and existing steel and/or concrete

CONTENTS

1. LINING SPECIFICATION
2. ENVIRONMENTAL CONDITIONS FOR APPLICATION
3. APPLICATION PROCEDURE
4. APPLICATION TECHNIQUES
5. TECHNICAL INSPECTION AND PROJECT CONTROL
6. GENERAL NOTES
 - 6.1. Steel Condition
 - 6.2. Steelwork Preparation
 - 6.3. Ventilation
 - 6.4. Heating
 - 6.5. Lighting
 - 6.6. Storage of Product at Point of Application
 - 6.7. Weather Shelters
 - 6.8. Abrasive Grit Blasting
 - 6.9. Cleaning
 - 6.10. Mixing
 - 6.11. Stripe Coating
 - 6.12. Pit Filling
7. REPAIR PROCEDURES
8. HEALTH & SAFETY

APPENDIX – FABRICATION RECTIFICATION

ID 399ABR_UK	Rev. 02a	Date 28/09/2016	Enviroline[®] 399ABR	Page 3 of 17
-----------------	-------------	--------------------	--------------------------------------	--------------

1. LINING SPECIFICATION

1.1 Surface Preparation

In common with most protective coatings schemes, the performance level of Enviroline 399ABR is ultimately determined by degree of surface preparation. The higher the degree of surface preparation achieved, the greater the long-term performance. For optimum performance, all surfaces to be coated should be clean, dry and free from contamination including dirt, salts, oil and grease.

Steel

Prior to paint application all surfaces should be assessed and treated in accordance with ISO 8504:2000. Where necessary, remove weld spatter and smooth weld seams and sharp edges (see Appendix 1). In cases where the substrate is corroded or pitted, it may be necessary to fresh water wash the areas after abrasive blasting, then re-blast, in order to ensure complete removal of soluble corrosion products.

The allowable total soluble salt contamination on the steel before application of the Enviroline 399ABR is as follows:

- Chlorides : Less than 3µg/cm²
- Sulphates : Less than or equal to 5µg/cm²
- Nitrates : Less than or equal to 5µg/cm²

The total of all 3 soluble salt types must not exceed 10µg/cm²

See section 3 for more details regarding measurement.

All steel surfaces to be coated should be correctly prepared prior to application of the coating system.

Abrasive grit blast the steel to be coated to a minimum of ISO Standard 8501-1 (2007) Sa2½ or SSPC SP10. A sharp and angular surface profile of between 75 and 125 microns (3-5mils) is required. In certain aggressive service conditions, it may be required to blast to Sa3 or SSPC SP5. Contact International Protective Coatings for specific advice.

Concrete

New concrete shall be properly cured prior to the application of Enviroline 399ABR. Laitance and efflorescence shall be removed. Moisture content must also be checked to make sure it is below 7% prior to coating application. The tensile strength of the concrete should be minimum 2MPa (300psi).

The presence of oil, grease and release agents in concrete may cause loss of coating adhesion. Although the surface may appear free of any oil, solvents in the coating material can draw the oil from within the concrete to the coating/concrete interface. Surface preparation of concrete should be done in accordance to SSPC-SP13/NACE 6. All chemical contamination must be removed prior to the application of Enviroline coating systems. Contamination includes efflorescence, laitance, oils, chemicals, acids, salts, alkalis, curing compounds, form release agents, and microorganisms.

ID 399ABR_UK	Rev. 02a	Date 28/09/2016	Enviroline® 399ABR	Page 4 of 17
-----------------	-------------	--------------------	---------------------------	--------------

All existing coatings and sealers must be removed to insure proper bond between the concrete substrate and lining. Concrete structures that have mechanical or chemical damage, or rebar corrosion must be restored to provide a uniform substrate for the coating.

The presence of severe hydrostatic forces may disbond the coating. The concrete substrate should have a vapor barrier on the soil side to prevent hydrostatic forces. Consult a qualified engineer to determine if these forces are present. If so, it is recommended a test patch be applied to test the bond strength and evaluated over a reasonable period of time.

A good blast profile is required to ensure the adhesion of coatings. Depending on condition of the concrete, a combination of chemical cleaning and/or abrasive blasting may be required. Previously applied coating will require abrasive blasting for removal.

Dry blasting is recommended. Blasting will remove loose and powdery concrete and surface laitance. The resulting surface must be hard, with surface voids open and with a profile that is satisfactory for coating adhesion.

The blast nozzle must be kept at a distance that will provide good results without gouging the concrete. The resulting surface should be at least as rough as 50-100 grit sandpaper or refer to ICRI profile standards. All dust and debris must be removed after abrasive blasting.

Dry, oil-free air must be used for the blasting operation. Use ASTM Method D4285 for determination of oil and water in compressed air sources.

Final cleaning methods must ensure that the surface is free of any cleaning agents or other surface contaminants. This may be accomplished by a compressed air blow down, vacuuming, dry wipe down or other appropriate final cleaning methods. The surface must be allowed to dry adequately for compatibility with the coating material.

Impact tools (scabblers and scarifiers), vacuum grit blasting, and power grinding may also be used for roughening concrete, opening holes and voids, and to remove loose matter from the surface of poured concrete and precast slabs. These methods may be used instead of blasting but are slower.

An appropriate primer is required to effectively seal the concrete substrate. Consult International Protective Coatings for specific advice on primer choice.

When working outside or in direct sunlight, concrete 'gassing' or 'breathing' can occur, when the surface temperature rises due to exposure to sunlight or increasing ambient temperatures. This can cause bubbles or holes in the applied coating. When this problem occurs, it is necessary to shade the surface from the sun and/or apply the material in the evening or at night, so that initial cure can take place in cooler temperatures, without air escaping from the concrete.

A detailed concrete surface preparation guideline document is available upon request

ID 399ABR_UK	Rev. 02a	Date 28/09/2016	Enviroline® 399ABR	Page 5 of 17
-----------------	-------------	--------------------	---------------------------	--------------

1.2 Typical Specification

<u>Coat</u>	<u>Product</u>	<u>Dft (microns)</u>			<u>Dft (mils)</u>		
		Spec	Min	Max	Spec	Min	Max
Stripe**	Enviroline 399ABR	175	125	250	7	5	10
Full	Enviroline 399ABR	950	(500)	(1250)	35	(20)	(50)

**All areas itemised in Section 6.11 are to receive a stripe coat.

1.3 Notes

The detailed project coating specification provided by International Protective Coatings must be followed at all times. This will include specific details with regard to surface preparation and dry film thickness requirements.

Specific project requirements will be dependent upon the service end use and operating conditions of the tank or vessel. Always consult International Protective Coatings to confirm that Enviroline 399ABR is suitable for contact with the product to be stored.

Refer to the Enviroline 399ABR datasheet for precise overcoating intervals, pot life and curing requirements.

2. ENVIRONMENTAL CONDITIONS FOR APPLICATION

Enviroline 399ABR will not cure at ambient temperatures below 13°C (55°F). For maximum performance, the temperature should be greater than 13°C (55°F). Humidity control is required during application of Enviroline 399ABR. The climatic conditions should be controlled to maintain a maximum relative humidity of 80% and a minimum temperature of 13°C (55°F). Maximum steel temperature should be no more than 49°C (120°F).

Application should not take place when relative humidity is more than 80% or the surface temperature is less than 3°C (5°F) above the dew point.

Dehumidification, air conditioning and/or heating equipment may be necessary to control environmental conditions but care should be taken when choosing heating methods, as some heaters can increase the local relative humidity.

For higher temperatures, for example those found in the Middle East and tropical areas consult your regional International Paint Technical Department.

3. LINING APPLICATION PROCEDURE

Defective steelwork, prior to contract commencement, should be repaired in line with the guidance notes given in the Appendix of this document.

Microclimate should be monitored in between applications. Changes in microclimate may affect overcoating intervals.

ID 399ABR_UK	Rev. 02a	Date 28/09/2016	Enviroline[®] 399ABR	Page 6 of 17
-----------------	-------------	--------------------	--------------------------------------	--------------

For steel surfaces, grit blast the steel to be coated to a minimum of ISO Standard 8501-1 (2007) Sa2½ or SSPC SP10. A sharp and angular surface profile of between 75 and 125 microns (3-5mils) is required. In certain aggressive service conditions, it may be required to blast to Sa3 or SSPC SP5. Contact International Protective Coatings for specific advice.

For concrete surfaces, carry out appropriate preparation as described in Section 1.

Upon completion of the surface preparation process, and following inspection by the Contractor Quality Control Department, an International Paint Technical Service Representative may also inspect the whole area and mark up any substandard areas if agreed as part of the contract.

Before coating of the blasted surfaces commences, the amount of residual salt should be measured using an appropriate method such as the Bresle Patch (ISO 8502-6), Chlor*Test CSN Salts test kit or similar. The number of tests to be carried out is dependent upon the size of the tank. If the residual salt level is greater than that agreed, the entire area to be coated should be fresh water washed and retested.

All marked areas shall be brought up to the required standard. The whole blasted area is to be blown down/vacuum cleaned to remove all dust and contamination.

Ensure, prior to application, that the minimum environmental conditions specified in Section 2 are achieved. Provision should be made to ensure these conditions are maintained throughout the painting program.

All areas itemised in Section 6.11 are to receive a stripe coat. The stripe coat should be applied within the overcoating intervals specified in the Enviroline 399ABR technical datasheet.

All the areas are to receive a full coat of Enviroline 399ABR to the specified dry film thickness.

When fully hard dry, and accepted by the Contractor Quality Control Department, an International Paint Technical Service Representative may confirm the dry film thickness if agreed as part of the contract.

Any areas of under thickness are to be brought up to the minimum thickness specified. This must be carried out within the overcoating intervals specified for the product. If the overcoating interval has been exceeded then the area should be abraded and cleaned prior to application of touch up.

Unless otherwise advised, all damages are to be either vacublasted to Sa2½ (ISO 8501-1 (2007)) or SSPC SP10 or Power tool clean to SSPC SP11 with a profile of 75-100 microns (3 -4 mils). All damages are to be touched up with Enviroline 399ABR to the specified minimum dry film thickness as per the project specification.

Upon completion of installation, the final coating should be inspected using a suitable non-destructive magnetic gauge to verify average lining thickness. Holiday testing and Shore D hardness testing should also be carried out.

Following testing, any defective area should be repaired in accordance with the recommendations of the International Paint Technical Service Representative. These recommendations will be based upon those outlined in Section 7.

Ensure that fresh containers are used after each unit is sprayed – do not refill the old containers.

ID 399ABR_UK	Rev. 02a	Date 28/09/2016	Envioline[®] 399ABR	Page 7 of 17
-----------------	-------------	--------------------	-------------------------------------	--------------

4. APPLICATION TECHNIQUES

Envioline 399ABR can be applied by either Single Leg Airless Spray (Hot Potting Method) or Plural Component Airless Spray

Envioline 399ABR should be applied via either method except for stripe coats where brush or a combination of airless spray and brush can be generally used.

Available air pressure and capacity for spray equipment should be at least 7kg/cm² and 7.0m³/min (100 psi and 250 cfm free air volume).

All spray equipment must be in good working order.

For both airless and heated plural component application, in cold and/or windy weather, insulate the exposed pumping equipment using pipe insulation or similar insulating material to reduce unit heat loss.

Single Leg Airless Application (Hot Potting)

The single leg airless spray method requires constant attention to temperature and pot life as the material is mixed prior to passing through the pump. It is important to remember that the higher the mixing temperature the shorter the pot life.

It is recommended that airless spray pump ratios of 56:1 or greater should be used. Smaller pumps may not be able to physically push the material through the lines and spray gun at an adequate rate. Teflon packings are recommended.

Remove suction tube and all filters from the spray unit and airless spray guns

Reversible tips should be the size range 31-36 thou (0.78 – 0.91mm). Tips must not be in a worn condition.

Paint line (hose) should be of 13mm, (½ inch), diameter, a maximum length of 45m (148ft), with a 10mm, (3/8 inch), diameter and 3m (10ft) whip-end. Both line and whip-end should be rated at 5000psi (351 kg/cm²)

The use of trace heated lines or an inline heater is recommended to maintain the temperature required for application (35-37°C, (95°F – 100°F))

Recommendations for the paint crew for single leg airless spray application are as follows:

The application crew should consist of a minimum of four (4) trained crew members. The crew should thoroughly understand the basics of the equipment, the material and the application techniques. The contractor may require fewer personnel on smaller projects. Recommendations for distribution of personnel are - two (2) inside of the tank and two (2) on the outside of the tank. The personnel inside of the tank being responsible for proper spraying, wet film thickness readings, and paint line (hose) movement. The outside personnel being responsible for the proper preheating, mixing of material, temperature monitoring once product is mixed, and dispensing of material to the pump.

It is recommended that periodic flushing of the pump, hose, and spray gun with Envioline 71C is carried out. If material reaches 54°C (130°F) during any part of the application process it is recommended that application be halted and the pump cleaned out immediately to reduce the risk of hardening in the pump, lines and gun

ID 399ABR_UK	Rev. 02a	Date 28/09/2016	Enviroline® 399ABR	Page 8 of 17
-----------------	-------------	--------------------	---------------------------	--------------

Plural Component Airless Application

Heated plural component spray application is the most practical and preferred method when working with fast curing, short pot life materials, especially when lining large areas and applying at lower temperatures.

A pump capable of accurately delivering a 2:1 mix ratio is essential (Graco 56:1 or greater power ratio is recommended).

Remove all filters from the spray unit and airless spray guns

Two (2) ½" x 12 elemental in-line static mixers are required – these are located in line after the mixer manifold on the plural component equipment.

Heated tanks and heated lines up to 55°C (130°F) may be necessary.

The resin (Part A) fluid line should be 13mm (½") internal diameter minimum. The hardener (Part B) fluid line should be 13mm, (½") internal diameter, although 10mm, (3/8") internal diameter minimum is also possible.

The high pressure solvent fluid line should be 6mm, (¼"), internal diameter minimum.

Tips should be the size range 31-36 thou (0.78 – 0.91mm) – reversible tips are suggested

Paint line (hose) should be 13mm diameter (½ inch), maximum length 45m, with a 10mm (3/8 inch) diameter, 3m (10ft) whip-end. Both line and whip-end should be rated at 5000psi (351 kg/cm²)

Plural component application requires volumetric check of the mix ratio (utilizing a ratio monitoring system) before and during the application process, although any variation in product colour during application will also indicate that the plural pump is off ratio.

The plural component unit should have facility for heating of the base and curing agent components.

The base component (part A) should be heated to a maximum of 55°C (130°F) and the hardener to a maximum of 40°C (105°F) under agitation in the plural component equipment.

The use of trace heated lines or an inline heater may be required to maintain the temperature required for application.

Recommendations for the paint crew for plural component airless spray application are as follows:

The application crew should consist of a minimum of four (4) trained crew members. The crew must thoroughly understand the basics of the equipment, the material and the application techniques. The application crew should consist of an equipment operator, one person to load preheated material into pump, a mixing manifold operator (who can take wet film thickness readings and move the paint line), and a gun operator. Equipment operator should monitor operation of equipment at all times to ensure proper performance. The mixing manifold operator should monitor the manifold gauges to ensure proper mix ratio and continuous pressure delivery. The gun operator should continuously monitor spray fan and material colour for consistency. Arrange equipment and all possible work to allow the gun operator to spray continuously.

Protective Coatings

All products supplied and technical advice or recommendations given are subject to our standard Conditions of Sale.



ID 399ABR_UK	Rev. 02a	Date 28/09/2016	Enviroline® 399ABR	Page 9 of 17
-----------------	-------------	--------------------	---------------------------	--------------

Important Note: A pressure drop is associated with paint lines. This pressure drop needs to be considered and depends upon the following factors.

- The viscosity of the paint. Higher viscosity paints produce greater pressure drops than low viscosity paints.
- The length of the paint line. Longer lines produce greater pressure drops
- The internal diameter of the paint line.
- Flow rate of paint through the line.

5. TECHNICAL INSPECTION

Project control via regular inspection and agreement on any future action is vital to a successful coating project, and in maximising the potential of a lining system.

All parties involved in the coating work must agree an inspection procedure prior to work commencing, this should outline how and when both work and inspection will be undertaken.

Prior to commencing the project, the contractor(s) must be provided with copies of the relevant product data sheets. Attention should be drawn to pack sizes, mix ratios, thinning restrictions, required application conditions etc.

Inspection equipment for measurement of profile depth, humidity, wet and dry film thickness, etc should be of suitable type and should be within calibration limits.

NOTE: When measuring the dry film thickness of coatings, the d.f.t. gauge must be calibrated prior to use as follows:

1. Check that the probe is clean.
2. Place the probe on a sample of millscale-free smooth steel of thickness greater than 1mm.
3. Calibrate the instrument to zero.
4. Select a certified shim of similar thickness to that expected for the coating under test.
5. Calibrate the gauge to the shim thickness.
6. Check that the gauge reads zero when replaced on the smooth steel sample.

Measurement of dry film thickness is described in ISO Standard 2808:1991 - Method 6A. or SSPC PA2

Holiday testing should be carried out to ensure the coating is free from voids according to NACE SP0188-2006 High Voltage Spark Testing at a test voltage of 100 volts per 25µm (1 mil)

Hardness – Conduct a Shore D Hardness test in accordance to ASTM D2240-05 to verify that Enviroline 399ABR has cured to the appropriate hardness. Shore D Hardness readings should be a minimum of 75 to indicate full cure.

The fully cured lining system should be uniform in colour and gloss and be relatively free of any runs, sags, porosity, pinholes, fisheyes, soft spots and debris

6. GENERAL NOTES

6.1 Steel Condition

Prior to commencement of gritblasting it is essential that the steel is clean, dry, and in a condition suitable for surface preparation and application of the coating scheme. All grease and oil must be removed from all surfaces and all hot work must be complete.

Protective Coatings

All products supplied and technical advice or recommendations given are subject to our standard Conditions of Sale.



ID 399ABR_UK	Rev. 02a	Date 28/09/2016	Enviroline[®] 399ABR	Page 10 of 17
-----------------	-------------	--------------------	--------------------------------------	---------------

Defective steelwork, prior to contract commencement, should be repaired in line with the guidance notes given in Appendix 1.

6.2 Steelwork Preparation

Preparation grades of welds, cut edges and surface imperfections are described in ISO 8501-3. Preparation to P3 grade of this standard will provide surfaces which will ensure optimum paint performance. International Paint recommends the following methods and minimum levels of preparation on any new steelwork. Please see Appendix concerning rectification of fabrication faults.

6.3 Ventilation

During and after coating application the ventilation system and trunking must be so arranged such that “dead spaces” do not exist. As solvent vapours are heavier than air, and will tend to accumulate in the lower areas and it is important that they are extracted from those areas. The extracted air must be balanced with fresh air being introduced into the encapsulated area.

Equipment used must not re-introduce abrasive dust, solvent vapour etc. into the area where the coated articles are stored.

The level of ventilation employed must take account of the Lower Explosive Limit (LEL) of the product being applied and comply with local legislative requirements. International Paint recommends that this is such that vapour concentrations do not exceed 10% of the LEL.

Venting to 10% of the LEL is considered to provide a reasonable margin of safety to allow for possible higher local concentrations. Care should be taken when setting up ventilation/extraction systems, to ensure that 10% figure is not exceeded.

Responsibility rests with the contractor to ensure that the requisite equipment is available and operated in such a way that these requirements are met. International Paint will provide all of the information needed to allow the contractor to calculate ventilation requirements. However, International Paint does not accept responsibility for the equipment, its operation, or the monitoring necessary to ensure that the requisite ventilation requirements are met.

All equipment used after the commencement of paint application must be electrically safe in operation.

6.4 Heating

If heating is necessary to satisfy the painting specification, it should be by means of a heat exchange system, i.e. air admitted to the encapsulated area should not pass directly through a combustion chamber.

6.5 Lighting

Lighting during painting must be electrically safe and provide suitable illumination for all work. As a general guide, lighting may be considered suitable if this text can be read at a distance of 30 centimeters from the eye.

Protective Coatings

All products supplied and technical advice or recommendations given are subject to our standard Conditions of Sale.



ID 399ABR_UK	Rev. 02a	Date 28/09/2016	Enviroline[®] 399ABR	Page 11 of 17
-----------------	-------------	--------------------	--------------------------------------	---------------

Ideally, the lighting should be powerful mains supplied spotlight with background lighting on at all times in the interests of safety.

Powerful mains spotlighting must be provided when inspection work is being carried out.

6.6 Storage of materials (at point of application)

Provision must be made for heated storage of the Enviroline 399ABR to ensure a temperature of 35°C (95°F) is achieved for the part A and 30°C (86°F) for the part B prior to application.

6.7 Weather Shelters

Weather shelters should be made available to cover application equipment during mixing and application of material. This should also prevent contamination from entering the area where application is underway.

6.8 Abrasive Grit Blasting

The steel surface should be grit blasted to a minimum standard ISO 8501-1 (2007) Sa2½ or SSPC SP10. In certain aggressive service conditions, it may be required to blast to Sa3 or SSPC SP5. Contact International Protective Coatings for specific advice.

In cases where the substrate is corroded or pitted, it may be necessary to fresh water wash the areas after abrasive blasting, then re-blast, in order to ensure complete removal of soluble corrosion products.

The maximum allowed total soluble salt contamination on the steel before application of the Enviroline 399ABR scheme is 100mg/m² (10µg/cm²)

Air used for blasting must be clean, oil free and dry. The pressure should be at least 7kgcm⁻² at the nozzle.

Abrasives used for blasting must be dry and free from dirt, oil, and grease and suitable for producing the standard of cleanliness and profile specified. The abrasive must therefore be in accordance with the specifications given in ISO 11126 - Parts 1 to 8 and each delivery should carry a certificate of conformity to this specification.

If blasting abrasive is supplied on site without a certificate of conformity, the material should be tested by the yard or contractor in accordance with the methods given in ISO 11127 - Parts 1 to 7.

Particular attention should be given to ISO 11127 - Part 6, where the level of water soluble contaminants must not give a conductivity value greater than 25mS/m, and ISO 11127 - Part 7, where the level of water soluble chlorides must not exceed 0.0025% by weight.

Iron or steel abrasives can be used for in-situ open blasting. Specifications for metallic abrasives are given in ISO 11124 - Parts 1 to 4 and the corresponding test methods in ISO 11125 - Parts 1 to 7. If used, careful and thorough cleaning must be carried out at all stages of the operation to ensure that no abrasive remains on the steel as this may subsequently corrode.

ID 399ABR_UK	Rev. 02a	Date 28/09/2016	Enviroline® 399ABR	Page 12 of 17
-----------------	-------------	--------------------	---------------------------	---------------

The required amplitude of the blast profile depends upon the type of coating to be applied. Measurement on site should be by profile gauge or other mutually agreed instruments.

Measurement of surface profile using comparators is described in ISO 8503-2 using comparators detailed in ISO 8503-1. A medium 'G' type comparator should be used and a value of 55-95 microns (2.2 to 3.8 mils) is acceptable when measured by:

ISO 8503-3: Focusing microscope

ISO 8503-4: Stylus

When using a needle gauge such as the Elcometer 123, a value of 75-100 microns (3 – 4 mils), taking a maximum of 10 determinations, is ideal.

6.9 Cleaning

Prior to initial blasting inspection, the bulk of spent grit should be removed.

Any substandard areas should be identified and should be brought up to the specified standard.

Following provisional approval of the blast standard, ALL remaining traces of grit and dust should be removed from all areas.

Final approval of a substrate for coating application should be confirmed after final cleaning.

6.10 Mixing

Efficient mechanical stirrers for the correct mixing of paint must be used.

For single leg airless spray application (Hot Potting Method) the mixed paint must be between 35°C (95°F) and 38°C (100°F) upon completion of mixing. This is best achieved by heating of the individual components to between 30°C (86°F) and 35°C (95°F) in a thermostatically controlled storage facility.

The material (Part A, Resin, and Part B, Hardener) should first be pre-mixed in its own container to ensure proper dispersion of contents. Scraping the sides and bottom of the container is required. The hardener component, Part B should then be combined with the resin component Part A. This can be carried out in the 20 litre or 5-gallon container provided as part of the standard Enviroline unit, or in a separate hopper. The combined components should then be agitated until thoroughly mixed with one another, at 400-600 rpm's, checking to see if the combined component color is uniform and complete. Excessive rpm's will induce air into the mixture and is not recommended. The equipment recommended for mixing consists of a 13mm, (½"), drive reversible variable speed drill, an Enviroline mixing paddle or equivalent, and a thermometer. The temperature of the material should be monitored during mixing.

For plural component application the individual components should be heated to 30°C (86°F) and fully pre-mixed in its own container to ensure proper dispersion of contents prior to loading into the appropriate hoppers on the spray unit (this is to facilitate the circulation and heating required for application). Facility for continued mixing will assist in maintaining uniform temperature during application.

Protective Coatings

All products supplied and technical advice or recommendations given are subject to our standard Conditions of Sale.



ID 399ABR_UK	Rev. 02a	Date 28/09/2016	Enviroline® 399ABR	Page 13 of 17
-----------------	-------------	--------------------	---------------------------	---------------

6.11 Stripe Coats

Stripe coating is an essential part of good painting practice. Typical areas where stripe coats must be applied include

1. behind bars
2. plate edges
3. cut outs i.e. scallops, manholes etc
4. welds, chimes and seam areas
5. areas of difficult access
6. small fitments of difficult configuration
7. areas of pitting

Note: The above list is not comprehensive, all areas must be included. The following diagrams indicate key areas requiring stripe coating:

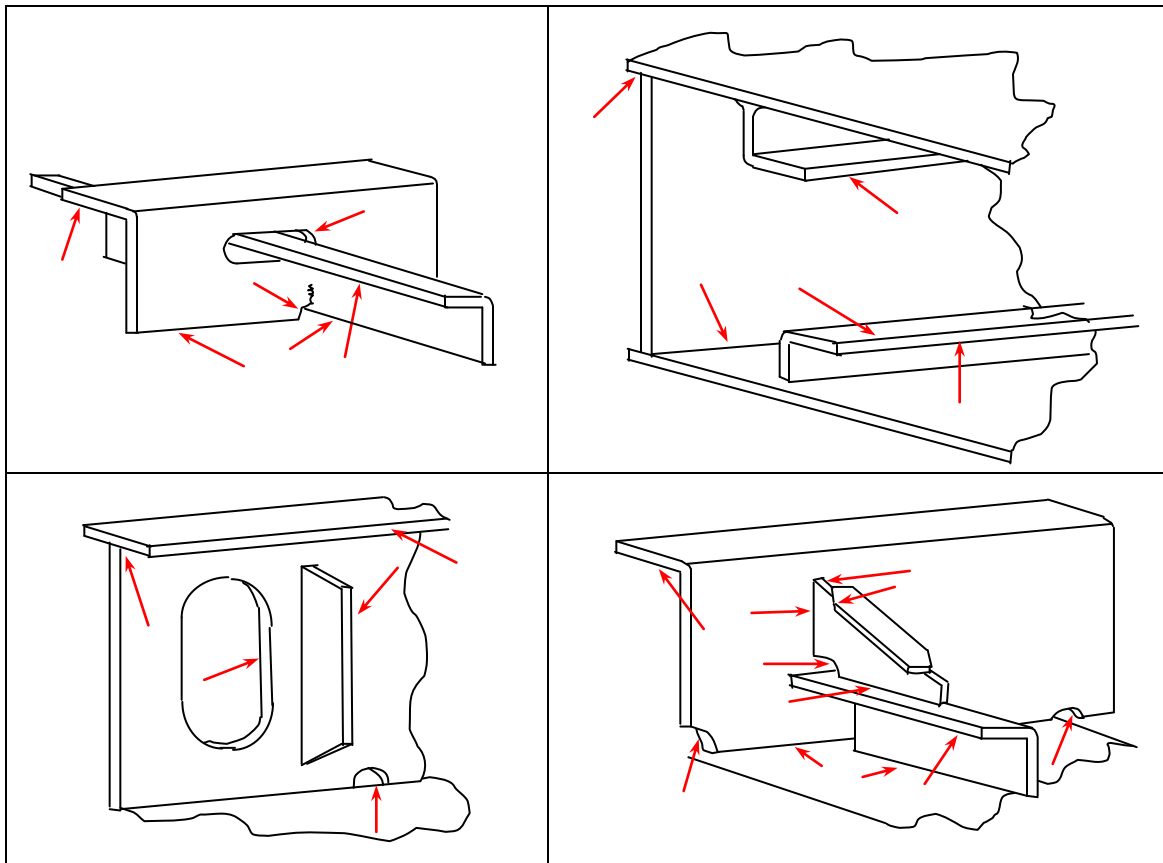

In general, stripe coats should be applied by brush. Application by roller should be limited to the inside of scallops.

In exceptional circumstances it may be acceptable to apply a stripe coat to the backs of angle bars by narrow angle spray. The use of spray applied stripe coats however, must be discussed and agreed with the International Paint representative on site. The stripe coat may be overcoated immediately "wet on wet" with Enviroline 399ABR

Protective Coatings

All products supplied and technical advice or recommendations given are subject to our standard Conditions of Sale.



ID 399ABR_UK	Rev. 02a	Date 28/09/2016	Enviroline[®] 399ABR	Page 14 of 17
-----------------	-------------	--------------------	--------------------------------------	---------------

6.12 Pit Filling

Areas showing deep pitting should be filled with Enviroline 399ABR prior to application of the full scheme. This can be best accomplished by spraying material over the pitted area and then ensuring penetration by use of a squeegee. The filled pits may then be overcoated “wet on wet” with Enviroline 399ABR although allowing a minimum of 15 minutes is recommended, to allow the material to flow into the pits, before overcoating.

7. REPAIR PROCEDURE

These repair guidelines are recommended for damages either at the initial coating stage or where breakdown of coating has occurred during service.

The repair procedure recommended will depend upon the extent of damage involved but can be split into major and minor areas.

7.1 Major Repairs

A major repair should essentially be dealt with as if the project were beginning. The recommendations given earlier for steel preparation, coating application, etc. must all be adhered to.

7.2 Minor Repairs

Under this heading are repairs to areas damaged either at the initial coating stage or caused during service. The principle requirements are:

The area to be repaired must be fresh water washed and dry.

Remove any corrosion by means of either:

- vacuum blasting (to achieve a minimum profile of 75µm, 3 mils)
- hand tools, i.e. disc sander and grinder to effectively roughen the coating surface

Any pitting which does not need re-welding should be prepared by needle gun and/or cone shaped grinder.

Abrade the area immediately surrounding the repair to provide key for subsequent paint application. Apply the paint system in accordance with the guidelines. If small areas are involved and application is by brush, several coats may be required to achieve the correct dry film thickness.

To repair an area of a tank that does not meet minimum thickness, brush blast, abrade (coarse grit), or grind the affected area to remove gloss and obtain a suitable surface roughness profile. Feather edges of repair site to achieve a smooth transition between repair and surrounding coating. Clean to remove any dust or debris prior to re-coating and solvent wipe with MEK. Allow solvent to evaporate. Spray or brush apply Enviroline 399ABR depending upon the size of the affected area, to obtain the proper thickness or to cover any discontinuities.

Holiday testing should be carried out to ensure the coating is free from voids according to NACE SP0188-2006 High Voltage Spark Testing at a test voltage of 100 volts per 25µm (1 mil)

Disposable solvent resistant brushes 2.5 to 10cm (1 to 4 inches) in width should be used for touch-ups and hard to reach areas only.

Protective Coatings

All products supplied and technical advice or recommendations given are subject to our standard Conditions of Sale.



ID 399ABR_UK	Rev. 02a	Date 28/09/2016	Enviroline® 399ABR	Page 15 of 17
-----------------	-------------	--------------------	---------------------------	---------------

8. HEALTH & SAFETY

8.1 Introduction

Whilst Enviroline 399ABR is ultra high volume solids, the aerosol droplets/particulates produced during airless spray of this material may form an explosive mixture with air and additionally may contain materials which may necessitate personal protection against potential health hazards. A summary of the main precautions to be taken includes:-

Danger of explosion or fire
 Provision of a suitable breathing environment for workers.
 Prevention of skin irritation problems.
 Use of paints which have been specially formulated for use in tanks.

8.2 Danger of Explosion or Fire

The key factors in preventing an explosion or fire are:

Adequate ventilation.
 Elimination of naked flames, sparks and any ignition sources.

8.3 Ventilation

Ventilation is necessary during abrasive blasting operations to ensure adequate visibility. Flexible trunking should be used to allow the point of extraction to be reasonably close to the personnel carrying out the blasting.

During and after coating application it is essential that solvent vapours are removed to ensure that the level present in the atmosphere does not rise above that recommended in the section (6.2) dealing with "Danger of Explosion and Fire". This means that the ventilation system must be arranged such that "dead spaces" do not exist and the ventilation must be continued both during the time that application is proceeding and also whilst solvent is released from the paint film during the drying process. Particular care must be taken to ensure that solvent vapour, which is heavier than air, does not accumulate in the lower areas of the tanks.

The amount of air per minute for ventilating to 10% of the LEL (lower explosive limit) can be regarded as the required air quantity multiplied by rate of application per minute. The required air quantity is the amount of air needed for each litre of paint to ventilate to the required level.

RAQ = Required Air Quantity
 LEL = Low Explosive Limit

International Paint should be contacted for RAQ and LEL values, which are also given on the Material Safety Data Sheets for the appropriate products.

Ventilation required (m³/minute) = RAQ x the application rate (litres/minute). The likely approximate application rate can be calculated from figures available from the application equipment supplier and will depend on the airless spray pump pressure and the orifice size of the tip used.

In the event of a failure of the extraction/ventilation system paint application must be stopped and the area evacuated of personnel immediately.

Protective Coatings

All products supplied and technical advice or recommendations given are subject to our standard Conditions of Sale.



ID 399ABR_UK	Rev. 02a	Date 28/09/2016	Enviroline® 399ABR	Page 16 of 17
-----------------	-------------	--------------------	---------------------------	---------------

8.4 Elimination of Ignition Sources

Safety is the overriding consideration with this type of coating work, and the Site Safety Department must be made fully aware of all aspects of the operation.

Welding, cutting or grinding in the immediate vicinity should be forbidden until paint fumes are totally dispersed. Lights, including hand torches, must be certified by the manufacturer as flash proof and suitable for use in solvent laden atmospheres.

Smoking must be prohibited in the area or near to extraction systems.

No electrical junction boxes should be allowed in the area where application is carried out.

Airless spray equipment must be earthed (because of the danger of static electricity build-up). Mobile telephones, electrical cameras, and any equipment that is not intrinsically safe, must not be used in the area or near to extraction systems.

8.5 Solvent Vapour and Paint Mists - Protection of Painting Personnel

No ventilation system can reduce solvent vapour levels to below the Occupational Exposure Limit for solvents whilst coating is in operation. Painters should, therefore, wear air fed hoods or pressure fed masks with additional eye protection. (Please note: air fed hoods which provide a curtain of air across the visor are available. These help to prevent settlement of spray mist on the visor). Normal protective clothing must be worn, e.g. overalls, gloves, and suitable footwear of non-spark type.

8.6 Skin Irritation

If proper protective clothing has been worn, e.g. overalls, gloves, air fed hood etc, no discomfort should be experienced from skin irritation. Any small areas not protected by clothing, e.g. wrists or neck, can be treated with a non-greasy barrier cream. (Petroleum jelly is not recommended as this can assist the transport of solvents into the skin).

Any areas of skin accidentally contaminated with paint must be thoroughly washed with soap and water. A skin conditioner that is designed to replace the natural oils in the skin can be used.

Note

1. The preceding safety information is given for guidance only.
2. It is imperative that, prior to the commencement of any tank coating project, local Regulations regarding Health and Safety be consulted.

ID 399ABR_UK	Rev. 02a	Date 28/09/2016	Enviroline® 399ABR	Page 17 of 17
-----------------	-------------	--------------------	---------------------------	---------------

APPENDIX – FABRICATION RECTIFICATION

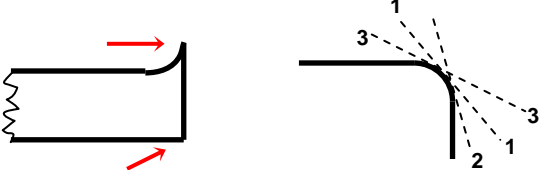
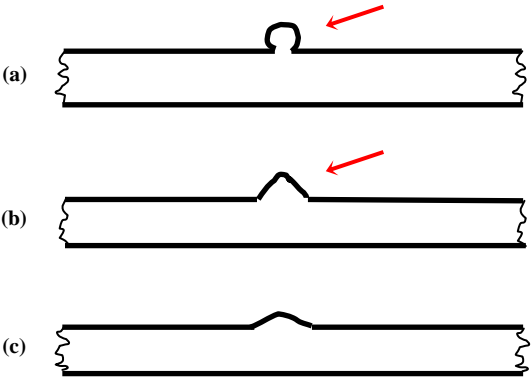
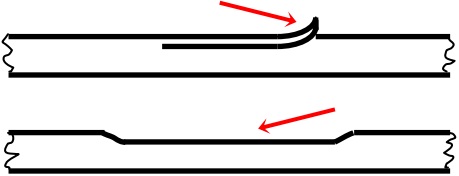
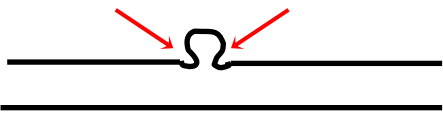
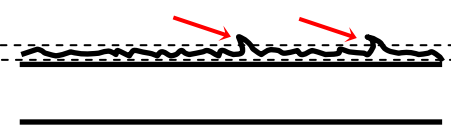
ITEM	PROBLEM/SOLUTION
Sharp Edge	<p>Remove sharp edges or gas cutting edges with grinder or disc sander to achieve a radius of 1.5mm-2.0mm</p> 
Weld Spatter	<p>Remove spatter observed before blasting by grinder, chipping hammer etc.</p> <p>For spatter observed after blasting: Remove with chipping hammer /scraper etc. Where spatter is sharp, use disc sander or grinder until obtuse Obtuse spatter – no treatment required</p> 
Plate Lamination	<p>Any lamination to be removed by grinder or disc sander</p> 
Undercut	<p>Where undercut is to a depth exceeding 1mm and a width smaller than the depth, repair by welding or grinding may be necessary</p> 
Manual Weld	<p>For welding bead with surface irregularity or with excessive sharp edges, remove by disc sander or grinder</p> 
Gas Cut Surface	<p>For surfaces of excessive irregularity, remove by disc sander or grinder</p> 